

MERCEDES ATEGO 7 HOLES DOUBLE GEAR UNI

MERCEDES ATEGO 7 DELİK AKTARMALI UNI

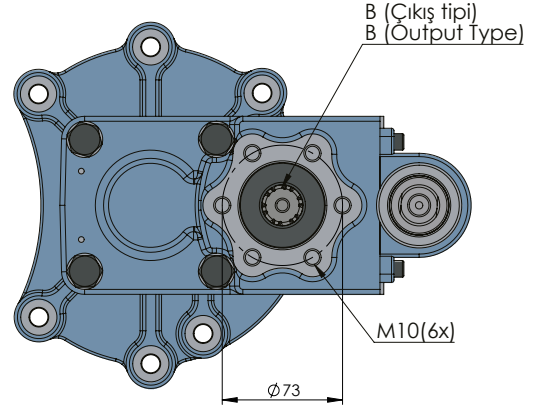
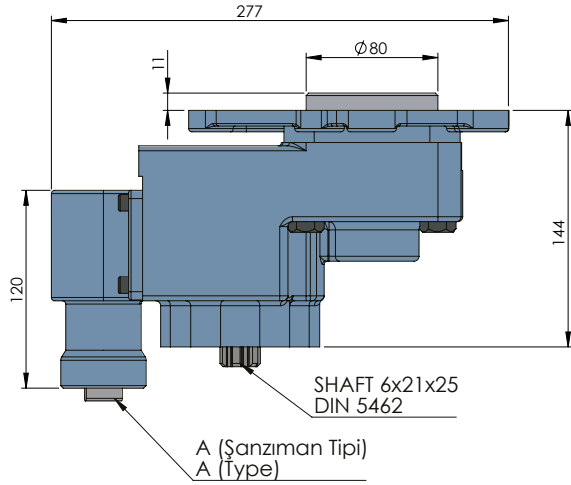
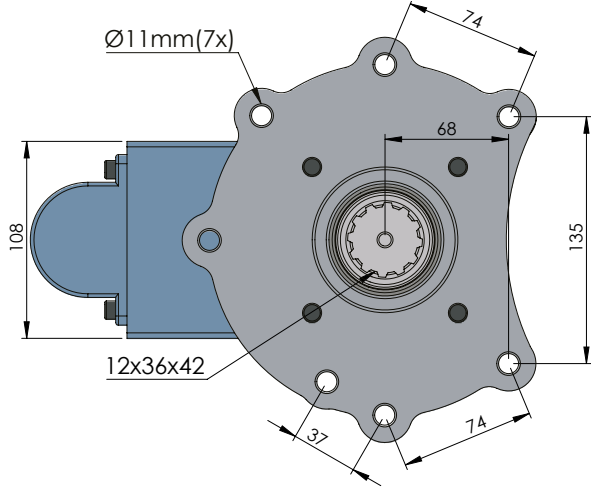

CODE KOD	TYPE TİP (A)	MOUNTING TYPE BAĞLANTI TİPİ (B)	MOUNTING SIDE BAĞLANTI	TORQUE TORK (Kgm / Nm)	POWER GÜÇ (Hp / Kw)	SPEED DEVİR (RPM)	RATIO ORAN
50122311P0	PNEUMATIC PNÖMATİK	UNI	REAR KUYRUK	22,4 Kgm 219,7 Nm	20 Hp 14,9 Kw	650	1:1,12
50122321P0		ISO ADAPTER ADAPTÖRLÜ ISO					
50122331P0		FLANGE FLANŞLI					
50122341P0		SHAFT ŞAFTLI					
GEARBOX / ANA ŞANZIMANLAR				USED VEHICLES / KULLANILAN BAZI ARAÇLAR			
G 60-6 (9,20) / G 85-6 (6,70) G 90-6 / G 71-6 / G 70-6				614-712-715-812-814-815-818-817-823-917-923-925-1017-1023-1328-1215-1217-1223-1225-1323-1325-1518-1528-2124-1317-1323-1328-1517-1523-1618-1623-1823 ATEGO / U 400 UNIMOG / 1118-1318-2124 ATEGO 2010 MODEL			